

Delta Geocoil - DGC

200-250-300 l.

EN



SAFETY INFORMATION
O&M INFORMATION
INSTALLATION MANUAL
TDS - TECHNICAL DATA SHEET

Manufactured by OSO Hotwater AS
Industriveien 1 - 3300 Hokksund - Norway
Tel: + 47 32 25 00 00 / Fax: + 47 32 25 00 90
E-mail: oso@oso.no / www.osohotwater.com

11002281-146050-04 - 06-2022

OSO
HOTWATER

CONTENTS

1. Safety instructions	3
1.1 General information	3
1.2 Safety instructions for users.....	4
1.3 Safety instructions for installers	4
2. Product description	5
2.1. Product identification	5
2.2. Intended use	5
2.3 CE marking.....	5
2.4 Technical data.....	5
2.5. ErP data (TDS).....	5
3. Installation instructions	6
3.1. Products covered by these instructions	6
3.2. Included in delivery.....	6
3.3. Product dimensions	6
3.4. Requirements for installation location	7
3.5. Pipe installation.....	8
3.6. Electrical installation	10
4. Initial commissioning	12
4.1. Filling with water	12
4.2. Turning on the power	12
4.3. Setting the mixer valve	12
4.4 Control points.....	12
4.5. Emptying of water.....	12
4.6. Handover to end-user.....	12
5. User Guide	13
5.1. Settings.....	13
5.2. Maintenance and annual inspection.	13
6. Troubleshooting	14
6.1. Faults and fixes.....	14
7. Warranty conditions	15
7.1. Warranty and registration.....	15
7.2. Customer service.....	15
8. Removing the product	15
8.1. Removal	15
8.2. Returns scheme	15



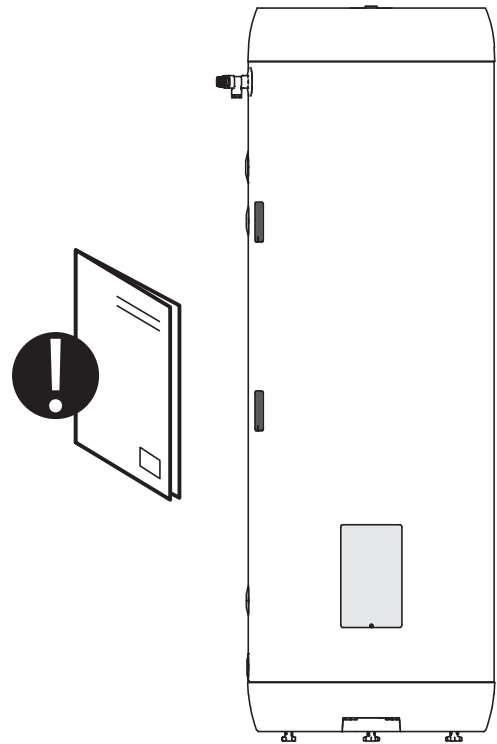

1. SAFETY INSTRUCTIONS

1.1 General information

- Read the following safety instructions carefully before installing, maintaining or adjusting the water heater.
- Personal injury or material damage may result if the product is not installed or used in the intended manner.
- Keep this manual and other relevant documents where they are accessible for future reference.
- The manufacturer assumes compliance (by the end-user) with the safety, operating and maintenance instructions supplied and (by the installer) with the fitting manual and relevant standards and regulations in effect at the date of installation.













Symbols used in this manual:

 WARNING	Could cause serious injury or death
 CAUTION	Could cause minor or moderate injury or damage to property
 DO NOT	
 DO	







 This document should be kept in a suitable place where it is accessible for future reference.





1.2 Safety instructions for users

 WARNING	
	The overflow from the safety valve shall NOT be sealed or plugged.
	The product shall NOT be covered over the cover on the front.
	The product shall NOT be modified or changed from its original state.
	Children shall NOT play with the product or go near it without supervision.
	The product shall be filled with water before the power is switched on.
	Maintenance/settings shall only be carried out by persons over 18 years of age, with sufficient understanding.

 CAUTION	
	The product shall not be exposed to frost, over-pressure, over-voltage or chlorine treatment. See warranty provisions.
	Maintenance/settings shall not be carried out by persons of diminished physical or mental capacity, unless they have been instructed in the correct use by someone responsible for their safety.

1.3 Safety instructions for installers

 WARNING	
	The overflow from the safety valve shall NOT be sealed or plugged.
	The discharge pipe from any safety device shall be at least one pipe size larger than the nominal outlet size of the safety device (< 9m length). The discharge pipe shall have continuous fall to drain, be uninterruptable and frost-free at all times.
	The electrical supply to the heater shall be done in accordance with current local regulations and best practice by a qualified electrician. The product is intended for permanent supply.
	The mains power supply cable shall withstand 90°C. A strain reliever shall be fitted.
	The product shall be filled with water before the power is switched on.
	The relevant regulations and standards, and this installation manual, shall be followed.

 CAUTION	
	The product shall be placed in a room with a floor drain. The manufacturer assumes no responsibility whatsoever if this provision is not followed.
	The product shall be properly aligned vertically and horizontally, on a floor or wall suitable for the total weight of the product when in operation. See type plate.
	The product shall have a clearance for servicing of 40 cm in front of the electric cover / 10 cm over the highest point.

2. PRODUCT DESCRIPTION

2.1 Product identification

Identification details for your product can be found on the type plate fixed to the product. The type plate contains details of the product in accordance with EN 12897:2016 and EN 60335-2-21, as well as other useful data. See Declaration of Conformity at www.osohotwater.com for more information.

OSO products are designed and manufactured in accordance with:

- Pressure vessel standard EN 12897:2016
- Safety standard EN 60335-2-21
- Welding standard EN ISO 3834-2

OSO Hotwater AS is certified for

- Quality ISO 9001
- Environment ISO 14001
- Work environment ISO 45001

2.2 Intended use

Delta Geocoil is designed to supply homes with hot running water. The product is intended for use with alternative energy sources.

2.3 CE marking



The CE mark shows that the product complies with the relevant Directives. See Declaration of Conformity at www.osohotwater.com for more information.

The product complies with Directives for:

- Low voltage LVD 2014/35/EU
- Electromagnetic compatibility EMC 2014/30/EU
- Pressurised equipment PED 2014/68/EU

Any safety valve(s) used should be CE-marked and comply with the PED 2014/68/EU.

2.4 Technical data

Prod. no.	Product code:	Capacity persons	Weight kg.	Dia. x Height mm.	Freight vol. m ³	Heating time hours Δt 65°C	Heat loss W
800 0325	DGC 200 - 2.8 kW / 1x230V+HX 2.6m ²	4,0	59	ø595 x 1270	0,49	-	58
800 0326	DGC 250 - 2.8 kW / 1x230V+HX 2.6m ²	5,0	73	ø595 x 1540	0,59	-	62
800 0328	DGC 300 - 2.8 kW / 1x230V+HX 3.1m ²	6,0	85	ø595 x 1750	0,66	-	69

The products are categorized as IP21.

2.5 ErP data - Technical Data Sheet

Brand	Model-no.	Model name	ErP profile	ErP Rating	Energy eff. %	AEC - kWh/a	Thermostat setting °C	Volume 40°C water
OSO Hotwater AS	800 0325	DGC 200 - 3 kW	-	B	-	-	70	-
OSO Hotwater AS	800 0326	DGC 250 - 3 kW	-	B	-	-	70	-
OSO Hotwater AS	800 0328	DGC 300 - 3 KW	-	B	-	-	70	-
Directive: 2010/30/EU Regulation: EU 812/2013			Directive: 2009/125/EC Regulation: EU 814/2013					
Heat loss tested acc. to standard: EN 12897								

3. INSTALLATION INSTRUCTIONS

3.1 Products covered by these instructions

- 800 0325 Delta Geocoil - DGC 200
- 800 0326 Delta Geocoil - DGC 250
- 800 0328 Delta Geocoil - DGC 300

3.2 Included in delivery

Ref no.	Number of	Description
1	1	PT safety valve
2	1	Hot water heater with built-in coil
3	2	Sensor slot
4	1	Thermostat
5	1	Heating element
6	1	Installation manual (this document)
7	3	Feet (factory-fitted)

3.3 Product dimensions

All dimensions in mm.

Product	A	B			∅
DGC 200	0-40	1270	675		595
DGC 250	0-40	1540	675		595
DGC 300	0-40	1750	675		595

Tolerance +/- 5 mm (not dimension A).

3.3.1 Connection heights

All dimensions in mm.

Product	C	D	E	F	H
DGC 200	155	316	926	926	1087
DGC 250	155	316	926	1191	1357
DGC 300	155	316	1231	1361	1567

Tolerance +/- 5 mm.

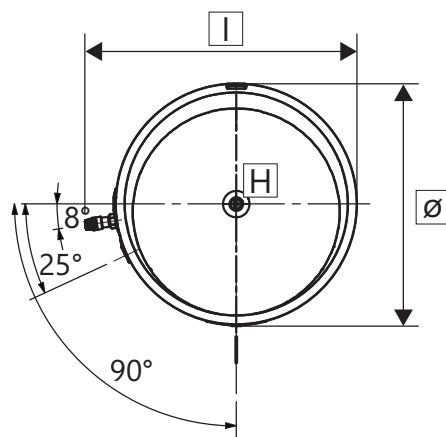
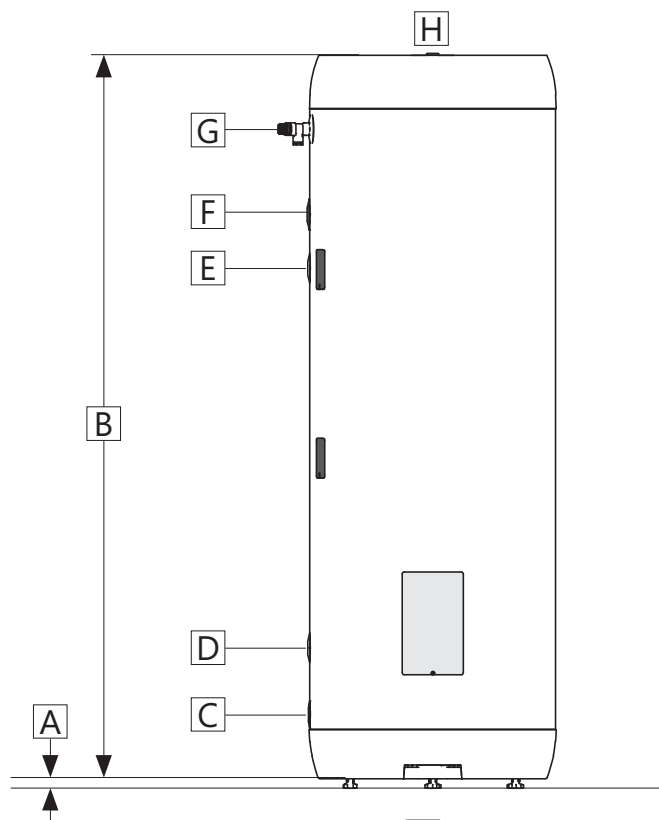
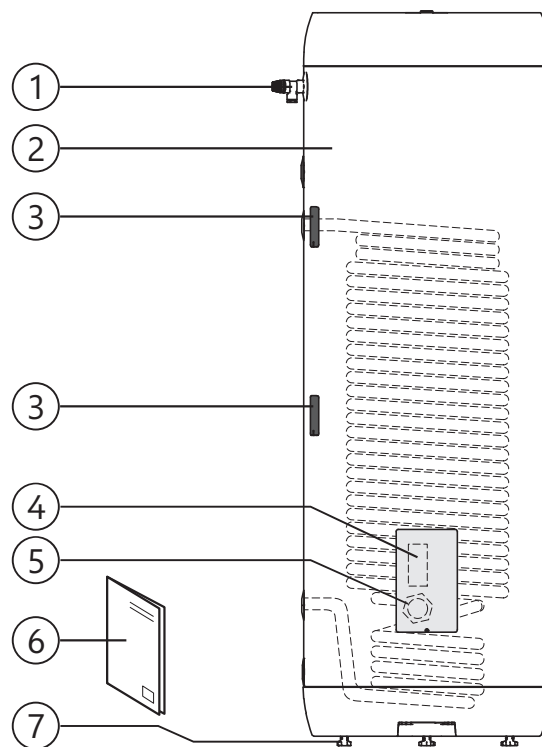

3.3.2 Delivery

The product should be transported carefully as shown, with packaging. Use the handles in the box.

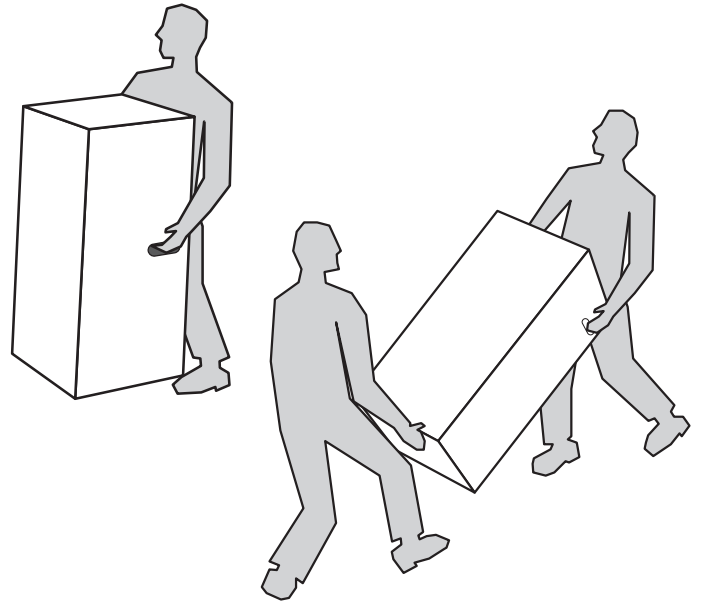

⚠ CAUTION
Pipe stubs, valves etc. should not be used to lift the product as this could cause malfunctions.

3.4 Requirements for installation location and positioning

⚠ CAUTION	
❗	The product shall be placed in a room with a floor drain. The manufacturer assumes no responsibility whatsoever if this provision is not followed.
❗	The product shall be placed in a dry and permanently frost-free position.
❗	The product shall be placed on a floor or wall suitable for the total weight of the product when in operation. See type plate.
❗	The product shall have a clearance for servicing of 40 cm in front of the electric cover / 10 cm over the highest point.
❗	The product shall be easily accessible in the home for servicing and maintenance.

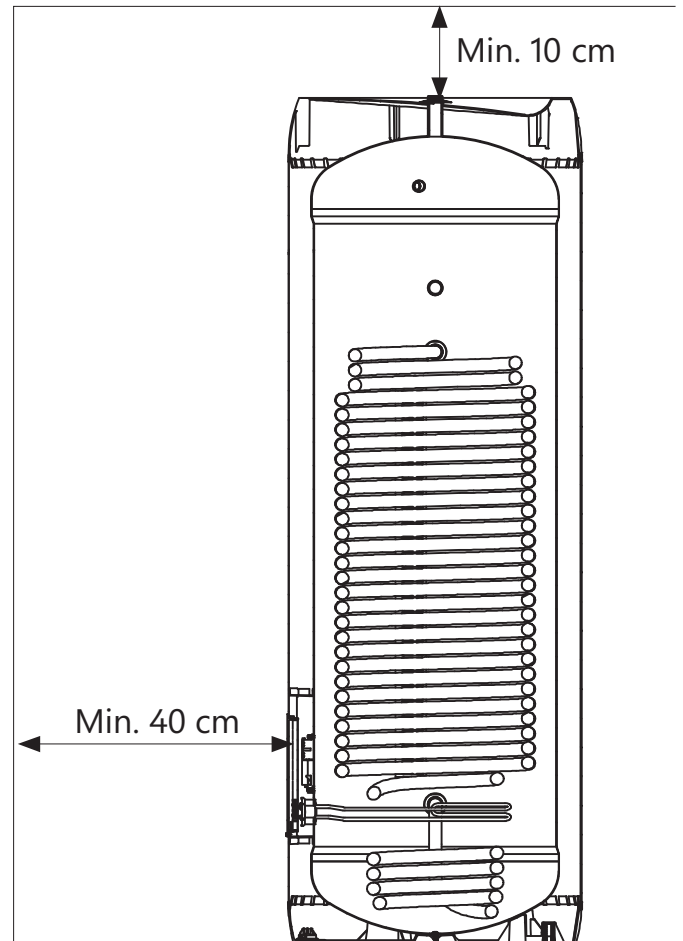
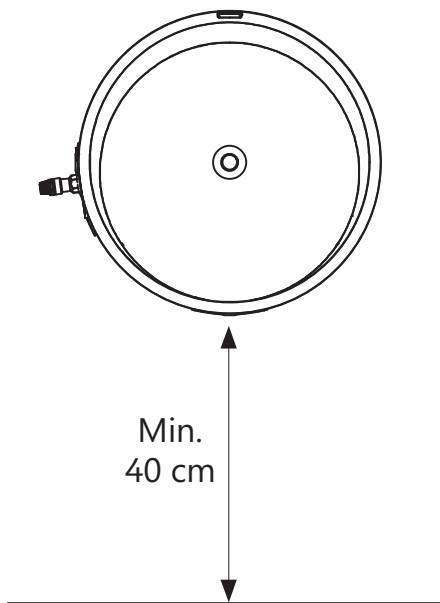

3.5 Pipe installation

The product is designed to be permanently connected to the mains water supply. Approved pipes of the correct size should be used for installation. The relevant standards and regulations must be followed.

3.5.1 Connections - dimensions and function

Connection	Dimension	Function
C	G3/4" internal	Cold water in
D	G3/4" internal	Coil connection, RETURN
E	G3/4" internal	Hot water circulation
F	G3/4" internal	Coil connection, FLOW
H	G3/4" internal	Hot water out
I	∅6 / 8 mm	Sensor slot
P	G1/2" internal	Safety valve P&T (supplied)

3.5.2 Incoming water pressure

The efficiency of the product depends on the incoming cold water pressure. The water pressure should be min. 2 bar and max. 6 bar throughout the day. Excessive water pressure can be adjusted by installing a pressure reduction valve.

3.5.3 Connecting pipes

Pipes of suitable size and quality should be run to the connections on the product and fixed with a suitable sealant.

A safety valve (see pt. 2.3) suitable for the installed effect in accordance with current local regulations shall be fitted in the heating circuit (not supplied).

3.5.4 Pressure drop table - coil

Delta Geocoil DGC 200 & 250 - Coil 2.6 m ²					
Flow L/hour	4500	3600	2700	1800	900
Pressure drop mBar	2100	1390	840	421	128
L/h @ 1 Bar pressure drop	3000				

Delta Geocoil DGC 300 - Coil 3.1 m ²					
Flow L/hour	4500	3600	2700	1800	900
Pressure drop mBar	2410	1610	946	479	150
L/h @ 1 Bar pressure drop	2800				

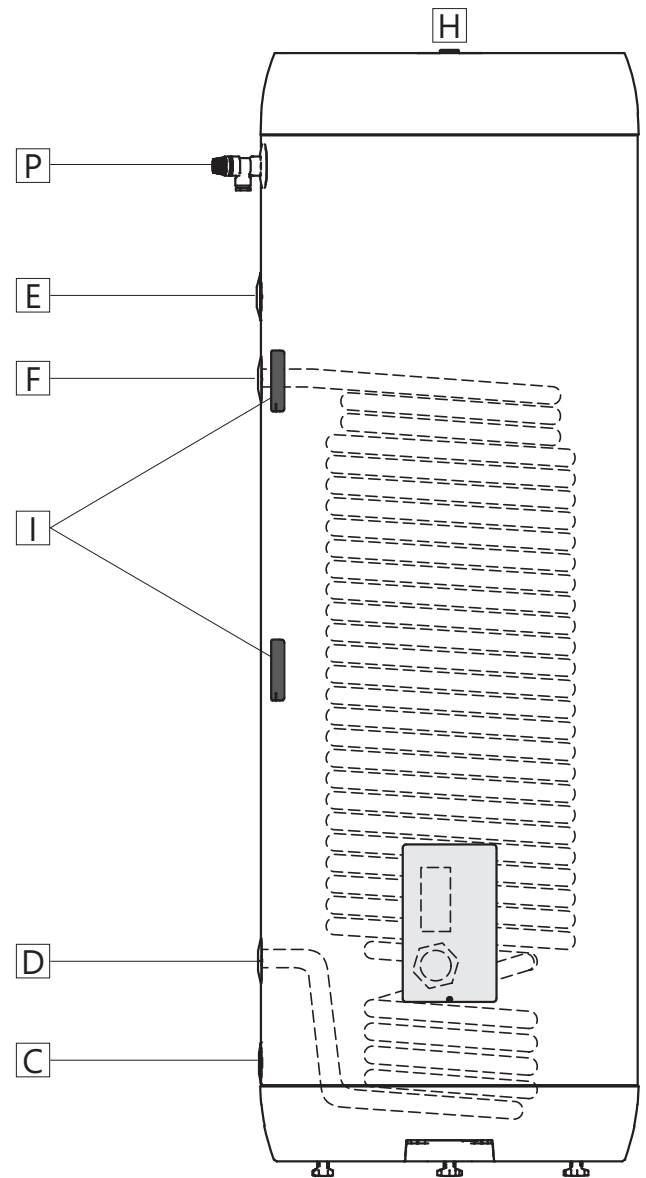

3.5.4 Fitting instructions

⚠ WARNING

❗	The product shall be filled with water before the power is switched on.
❗	The discharge pipe from any safety device shall be at least one pipe size larger than the nominal outlet size of the safety device (< 9m length). The discharge pipe shall have continuous fall to drain, be uninterrupted and frost-free at all times.

⚠ CAUTION

❗	The product shall be placed in a room with a floor drain. The manufacturer assumes no responsibility whatsoever if this provision is not followed.
❗	The product shall be properly aligned vertically and horizontally, on a floor or wall suitable for the total weight of the product when in operation. See type plate.
❗	The product shall have a clearance for servicing of 40 cm in front of the electric cover / 10 cm over the highest point.

3.5.5 Fitting recommendation

RECOMMENDATION

-	Allow clearance to the floor. Unscrew the feet a minimum of 15 mm out from the bottom of the product.
-	Mains power supply cable (1) should be hidden under one of the channels in the bottom of the product, as shown in illustration.
-	If a non-return valve is fitted a reduction valve and expansion vessel should be fitted to prevent dripping from the safety valve.
-	If the maximum water pressure exceeds 6 bar in a 24-hour period a reduction valve and expansion vessel should be fitted.

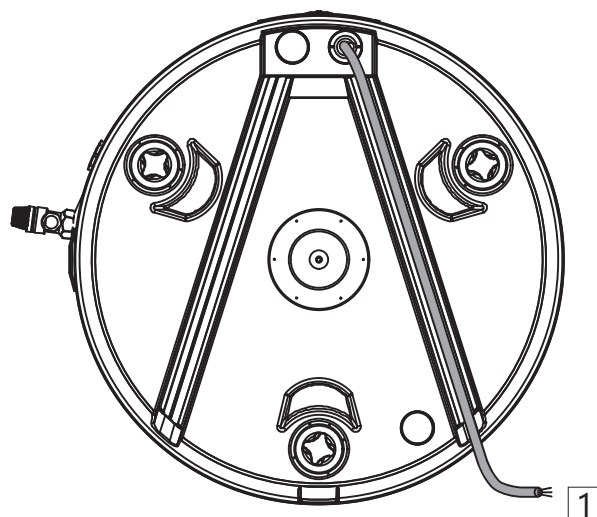

3.6 Electrical installation

The electrical supply to the heater shall be done in accordance with current local regulations and best practice by a qualified electrician. The product is intended for permanent supply.

3.6.1 Electrical components

Component	Note
Safety thermostat	85°C safety cut-off
Working thermostat	50-75°C adjustable
Heating element	2.8 kW - 1-phase 230V
Power supply cable	Heat resistant to 90°C
Internal wires	Heat resistant

3.6.2 Electrical connections in the junction box

⚠ WARNING

Constant voltage present at terminals L and N. Before any electrical work is done, the power supply must be disconnected and secured against activation while the work is in progress.

- A) Blue wire (L) – Live – connected to point 'A' on the thermostat.
- B) Brown wire (N) – Neutral – connected to point 'B' on the thermostat.
- C) Yellow wire with green stripe (⊕) – Earth – connected to the terminal for the heating element (hexagonal brass)

3.6.3 Torque settings

Component	Torque
G1.1/4" external - heating element	60 Nm (+/- 5)
Thermostat screws (A and B)	2 Nm (+/- 0.1)
Earth screw on the element head	2 Nm (+/- 0.1)

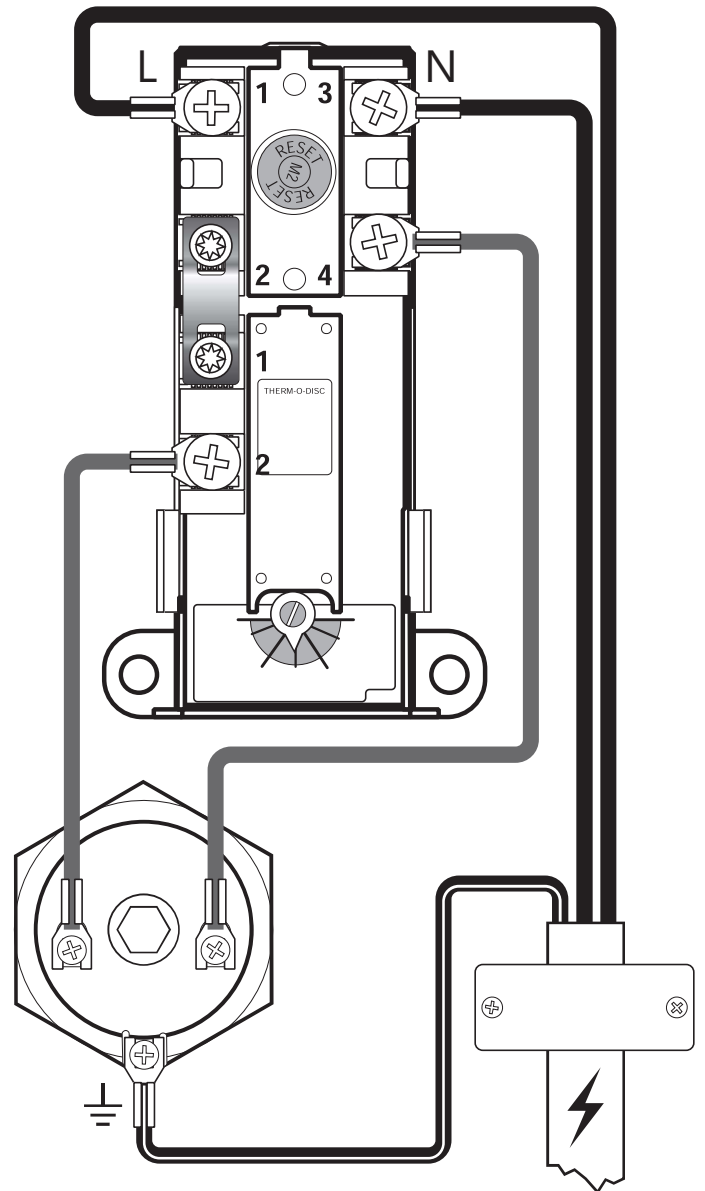

Electric connection, schematic

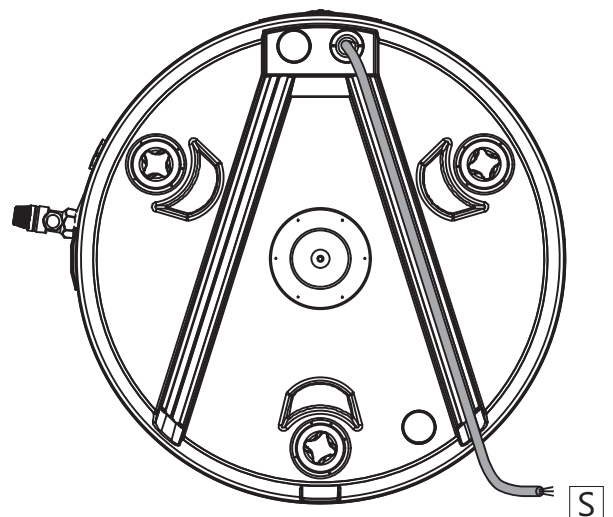

3.6.4 Fitting instructions

⚠ WARNING

❗	The product shall be filled with water before the power is switched on.
❗	The electrical supply to the heater shall be done in accordance with current local regulations and best practice by a qualified electrician. The product is intended for permanent supply.
❗	The mains power supply cable shall withstand 90°C. A strain reliever shall be fitted.

⚠ CAUTION

❗	The product shall have a clearance for servicing of 40 cm in front of the electric cover / 10 cm over the highest point.
❗	If the mains power supply cable is damaged, it shall be replaced with cable of a quality that meets the requirements of the installation. The cable must be replaced by a qualified electrician.

3.6.5 Fitting recommendation

RECOMMENDATION

-	The mains power supply cable (S) should be hidden under one of the channels in the bottom of the product, as shown in illustration on previous page.
-	For products with $\leq 2\text{kW}$ capacity, a $\geq 10\text{A}$ fuse / $\geq 1.5\#$ wire shall be used. For products with $\leq 3\text{kW}$ capacity, a $\geq 15\text{A}$ fuse / $\geq 2.5\#$ wire shall be used.

3.6.6 Temperature sensor installation

The product is equipped with a temperature sensor bracket which allows installation of a 6 or 8 mm. temperature sensor. To install the temperature sensor follow the instructions below.

1. Remove temperature sensor bracket (A) from tank body by gripping it and pulling straight out.
2. Insert temperature sensor (B) firmly into the appropriate grooves in the sensor bracket and place the temperature sensor cable in the cable slot (D).
An 8 mm. sensor (shown) fits in the upper grooves (C) while a 6 mm. sensor fits in the lower groove (E).
3. Refit the sensor bracket into the tank body, ensuring the bracket is inserted fully to establish proper contact between the sensor and the stainless steel inner tank surface. Make sure the sensor cable is positioned properly in the cable slot (D) to avoid potential damage to the cable.

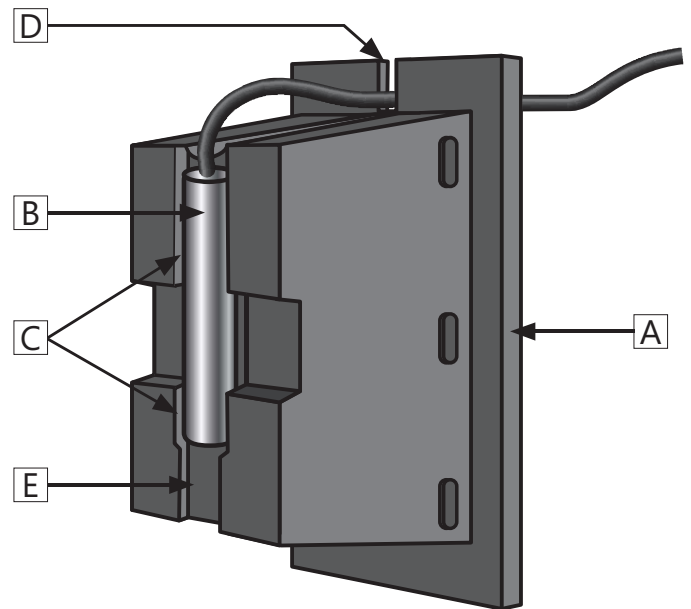

4. INITIAL COMMISSIONING

4.1 Filling with water

First check that all pipes are connected correctly. Then proceed as follows:

- A) Open a hot tap – leave it open
 - B) Open the cold water supply to the product.
- Check that the water from the open hot water tap is flowing freely, without any air locks. Close hot tap.

Filling/emptying coil: Follow the instructions for an external heat source.

4.2 Turning on the power

When the cylinder has been filled with water, the power can be switched on.

4.3 Control points

- A) Check that all pipe connections to/from the product are tight and not leaking.
- B) Check that the power supply to the product is not at risk of exposure to mechanical, thermal or chemical damage.
- C) Check that any overflow pipe from the safety valve is clear, undamaged and frost-free with a fall to the drain.
- D) Check that the product is standing firmly vertically and horizontally.

4.5 Emptying of water

⚠ WARNING

The water temperature in the product may exceed 75°C and could cause scalding. Before emptying, a hot tap should be opened to max. pressure/temperature for min. 3 minutes.

- A) Disconnect the power supply.
- B) Shut off incoming cold water supply.
- C) Open a hot tap to the maximum – leave open (prevents vacuum).
- D) Disconnect the pipes for the cold water feed (D) to the product. Product emptied.

Before the product is filled up again, the pipe for the cold water supply must be reattached to the connection (D) with a suitable sealant. Check that the connection is tight after the product is in operation.

4.5.1 Emptying the coil

Follow the instructions for the external heat source when emptying this. Then disconnect the return pipe from the coil. The coil is emp-

ied via the lower connection. Note: The coil has a riser (C) from the lowest point, where liquid is collected. To empty the coil completely compressed air has to be applied to the upper coil connection to drain off all the liquid.

4.6 Handover to end-user

THE INSTALLER MUST:

Brief the end-user on safety and maintenance instructions.

Brief the end-user on settings and emptying the product.

Hand this installation manual over to the end-user.

Enter contact details on the type plate on the product.

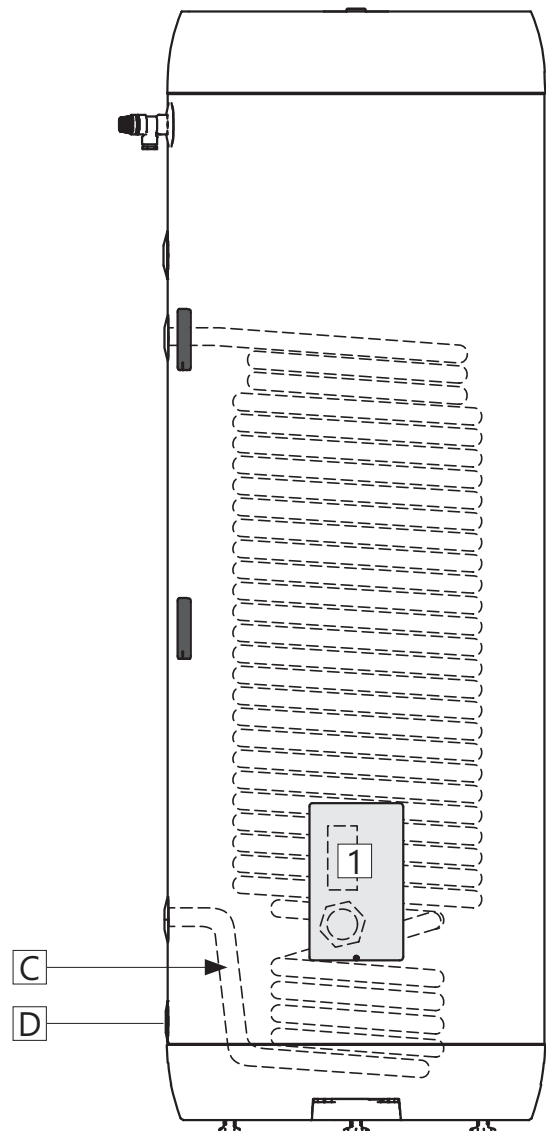

5. USER GUIDE

5.1 Settings

5.1.1 Thermostat setting

The thermostat on the product is adjustable from 50-75°C. The thermostat shall not be set lower than 60°C to prevent bacteria growth. To adjust the temperature:

- A) Disconnect the power supply.
- B) Remove the cover (1) with a screwdriver.
- C) Adjust the temperature on the thermostat with the adjustment dial (3).
- D) The thermostat is adjustable from 50-75°C. Refit the cover (1) before connecting the power supply.

5.1.2 Resetting the safety thermostat

The safety thermostat on the product cuts out when there is a risk of overheating. This is reset by removing the cover (1) and pressing the 'Safety' button (2). If the thermostat cuts out repeatedly, contact the installer.

5.1.3 Adjusting the feet

The product is equipped with three factory-fitted feet, adjustable from 0-40 mm. Unscrew the feet a minimum of 15 mm from the bottom of the product. Adjust the feet individually until the product is standing firmly vertically and horizontally.

5.2 Maintenance

All components of the product must be inspected annually by a person over the age of 18 with sufficient knowledge. The annual inspection includes:

- Checking that all connections and pipe fittings are tight and not leaking.
 - Tightening all connections in the electric junction box:
- A) Turn off power supply to the product and secure against activation while work is in progress.
 - B) Remove junction box cover (1) and tighten all connections, see torque settings in table 3.6.4.
 - C) Refit junction box cover (1) before turning power back on.
- Annual inspection of the safety valve must be performed according to procedure below.

⚠ WARNING

Constant voltage present in the junction box. Before any electrical work is done, the power supply must be disconnected and secured against activation while the work is in progress.

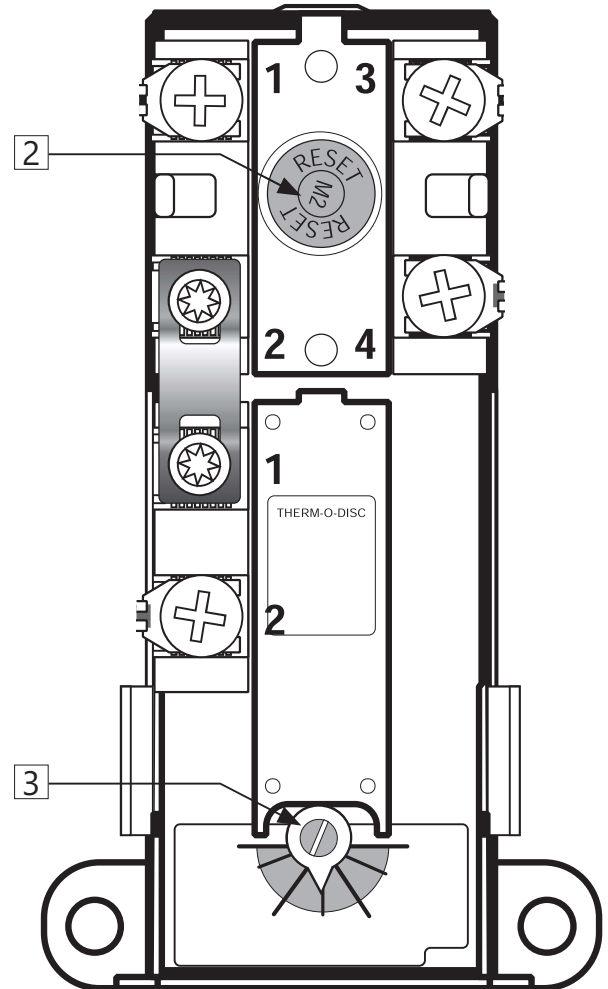

MAINTENANCE INSTRUCTIONS

⚠	Annual inspection of safety valve:	
-	Open valve for 1 min. by turning the knob (1) counterclockwise to the open position.	
-	Visually check that the water is flowing freely to the drain.	
-	YES = OK. Close the valve by turning knob (1) further clockwise until valve shuts.	
-	NO = NOT OK. Disconnect power supply / shut off water supply. Contact installer.	

6. TROUBLESHOOTING

6.1 Faults and fixes

If problems arise when the product is in use, check for possible faults and fixes in the table. If the problem is not shown in the troubleshoot-

ing table or you are unsure what is wrong, contact the installer (see type plate on the product) or OSO Hotwater AS - see section 7.1.

TROUBLESHOOTING		
Problem	Possible cause of fault	Possible solution
No hot water	Power supply interrupted.	Check that the fuse is set and the earth breaker has not tripped.
	Thermostat has cut out.	Press the 'Safety' button on the safety thermostat; see 'User guide'.
	Heating element is defective.	Replace heating element. Contact auth. installer.
	Leak in hot water pipe	Verify as follows: a) close all hot water taps, b) wait 2-3 hours, c) feel the hot water outlet pipe to see whether it is hot. If so, there is a leak in the hot water pipe or elsewhere. Contact auth. installer.
There is leakage/dripping from the safety valve/ there is often water on the floor by the cylinder in the morning	Pressure reduction valve, water meter or blocked non-return valve on the water intake.	Fit AX expansion vessel with absorbs expansion during heating, and fit pressure reduction valve for stable water pressure inside the home. The pressure reduction valve is adjusted in according to the pressure in the expansion vessel. Contact auth. installer.
	Water pressure into the home is too high.	
	The safety valve is worn or there are particles stuck between the membrane and the valve seat because the water is dirty	Try to flush with water through the safety valve. Open valve for approx. 1 minute. If the valve still leaks, it shall be replaced. Contact auth. installer.
	Leak from heating element.	Verify as follows: a) cut the electric supply, b) unscrew the cover, c) visually check whether there is a leak from the heating element. If so, replace the gasket/heating element. Contact auth. installer.
Not enough hot water	High consumption in the home.	Raise the temperature on the thermostat to 75°C; see 'User guide'.
		Switch to a larger OSO water heater. Contact auth. installer.
Not high enough temperature	The thermostat is set for low temperatures.	Raise the temperature on the thermostat to 75°C; see 'User guide'.
	Change from cold to hot water in taps.	Contact auth. installer.
Fuse/earth breaker trips repeatedly	Possible fault in the heater's electrical system.	Verify as follows: a) cut the electric supply, b) unscrew the cover, c) visually check the junction box for any problems. If so, contact auth. installer to check. Fit the cover.
Long time before the water reaches the tap	Long stretch of pipe from water heater to tap.	Fit circulation wire or heating cable to HW pipe. Or fit an auxiliary heater by the tap. Contact auth. installer.
Knocking in the pipes when the hot tap is closed	Large pressure increase when the tap is closed quickly.	Completely normal. Fit AX expansion vessel if troublesome. Contact auth. installer.

7. WARRANTY CONDITIONS

1. Scope

OSO Hotwater AS (hereinafter called OSO) warrants for 2 years from the date of purchase, that the Product will: i) conform to OSO specification, ii) be free from defects in materials and workmanship, subject to conditions below. All components carry a 2-year warranty.

The warranty is voluntarily extended by OSO to 5 years for the stainless steel inner tank. This extended warranty only applies to Products purchased by a consumer, that has been installed for private use and that has been distributed by OSO or by a distributor where the Products have been originally sold by OSO. The extended warranty does not apply to Products purchased by commercial entities or for Products that have been installed for commercial use. These shall be subject only to the mandatory provisions of the law. The conditions and limitations set out below shall apply.

2. Coverage

If a defect arises and a valid claim is received within the statutory warranty period, at its option and to the extent permitted by law, OSO shall either; i) repair the defect, or; ii) replace the product with a product that is identical or similar in function, or; iii) refund the purchase price.

If a defect arises and a valid claim is received after the statutory warranty period has expired, but within the extended warranty period, OSO will supply a product that is identical or similar in function. OSO will in such cases not cover any other associated costs.

Any exchanged Product or component will become the legal property of OSO. Any valid claim or service does not extend the original warranty. The replacement Product or part does not carry a new warranty.

3. Conditions

The Product is manufactured to suit most public water supplies. However, there are certain water chemistries (outlined below) that can have a detrimental effect on the Product and its life expectancy. If there are uncertainties regarding water quality, the local water supply authority can supply the necessary data.

The warranty applies only if the conditions set out below are met in full:

- The Product has been installed by a professional installer, in accordance with the instructions in the installation manual and all relevant Codes of Practice and Regulations in force at the time of installation.
- The Product has not been modified in any way, tampered with or subjected to misuse and no factory fitted parts have been removed for unauthorized repair or replacement.
- The Product has only been connected to a domestic mains water supply in compliance with the European Drinking Water Directive EN 98/83 EC, or latest version. The water

shall not be aggressive, i.e. the water chemistry shall comply with the following:

- Chloride	< 250 mg / L
- Electric Conductivity (EC) @25°C	< 750 uS / cm
- Saturation Index (LSI) @80°C	> - 1,0 / < 0,8
- pH level	> 6,0 / < 9,5

- The immersion heater has not been exposed to hardness levels exceeding 10°dH (180 ppm CaCO₃). A water softener is recommended in such cases.
- Any disinfection has been carried out without affecting the Product in any way whatsoever. The Product shall be isolated from any system chlorination.
- The Product has been in regular use from the date of installation. If the Product is not intended to be used for 60 days or more, it shall be drained.
- Service and/or repair shall be done according to the installation manual and all relevant codes of practice. Any replacement parts used shall be original OSO spare parts.
- Any third-party costs associated with any claim has been authorized in advance by OSO in writing.
- The purchase invoice and/or installation invoice, a water sample as well as the defective product is made available to OSO upon request.

Failure to follow these instructions and conditions may result in product failure, and water escaping from the Product.

4. Limitations

The warranty does not cover:

- Any fault or costs arising from incorrect installation, incorrect application, lack of regular maintenance in accordance with the installation manual, neglect, accidental or malicious damage, misuse, any alteration, tampering or repair carried out by a non-professional, any fault arising from the tampering with or removal of any factory fitted safety components or measures.
- Any consequential damage or any indirect loss caused by any failure or malfunction of the Product whatsoever.
- Any pipework or any equipment connected to the Product.
- The effects of frost, lightning, voltage variation, lack of water, dry boiling, excess pressure or chlorination procedures.
- The effects of stagnant (de-aerated) water if the Product has been left unused for more than 60 days consecutively.
- Damage caused during transportation. Buyer shall give the carrier notice of such damage.
- Costs arising if the Product is not immediately accessible for servicing.

These warranties do not affect the Buyer's statutory rights.

- A) The installer who supplied the product.
- B) OSO Hotwater AS: Tel.: +47 32 25 00 00
oso@oso.no / www.oso.no

7.1 Customer service

In case of problems that cannot be resolved with the aid of the troubleshooting guide in this installation manual, contact either:

8. REMOVING THE PRODUCT

8.1 Removal

- A) Disconnect the power supply.
- B) Shut off incoming cold water supply.
- C) Empty the product of water – see section 4.4.
- D) Disconnect all pipes.
- E) The product can now be removed.

8.2 Returns scheme

This product is recyclable and shall be taken to the environmental recycling centre. If the product is to be replaced with a new one, the installer can take the old cylinder away for recycling.

OSO

HOTWATER

OSO Hotwater AS

Industriveien 1
3300 Hokksund - Norway
Tel: + 47 32 25 00 00
oso@oso.no
www.osohotwater.com

© This installation manual and all its content is protected by copyright and may be reproduced or distributed only with written consent from the manufacturer. We reserve the right to make changes without notice.